

Item	Qty.	Description
1	1	40" Vertical Extrusion
2	1	40" Vertical Extrusion
3	1	40.418" Curved Extrusion
4	1	40.418" Curved Extrusion
5	1	40.418" Curved Extrusion
6/6A	1/1	23.55" Horizontal Extrusion

Steps:

- 1) Attach Curved Extrusions [3, 4, 5] to Verticals [1, 2], with Infills between as shown.
- 2) Attach Horizontals [6, 6A] between Verticals [1, 2].
- 3) Place lower Shelf on Lip of Curved Extrusion [4]. See [Extrusion Lip](#) detail.
- 4) Attach Shelf Supports to Velcro inside of assembled Pedestal base.
- 5) Place upper Shelf on top of Shelf Supports.
- 6) Place Pedestal Top on top of assembled Pedestal base. See [Pedestal Top Attachment](#) detail.

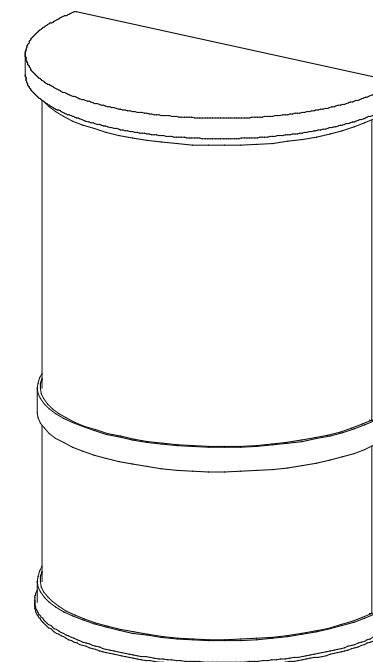
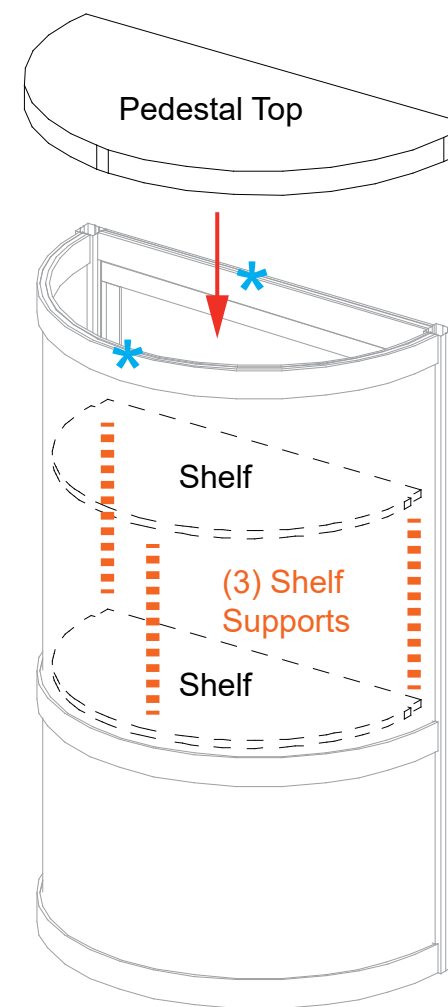
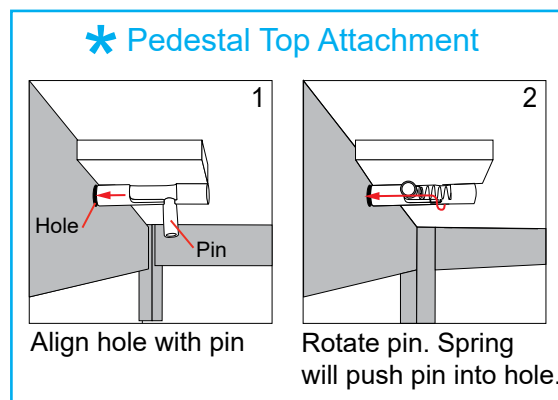
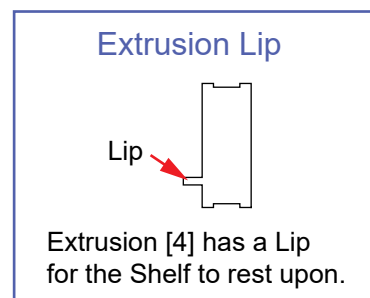
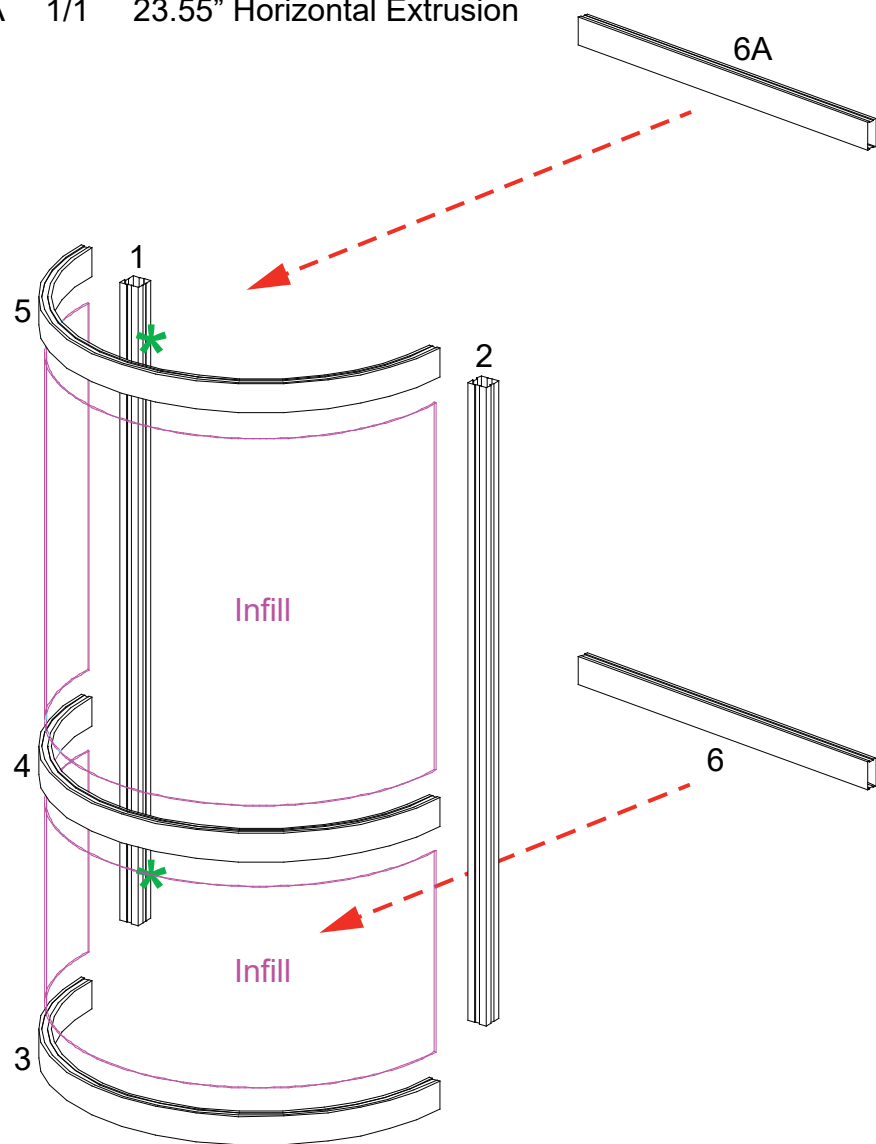

Completed Assembly

General Setup Instructions

- Read entire setup instruction manual prior to unpacking parts and pieces.
- The setup instructions are created specifically for this configuration.
- Setup instructions are laid out sequentially in steps, including exploded views with detailed explanation for assembly.

Cleaning & Packing

- For Cleaning Metal, Plex, & Laminate Parts: Use a **MILD NON-ABRASIVE** cleanser and soft cloth/paper towel to clean all surfaces.
- Keep exhibit components away from heat and prolonged sun exposure. **Heat and UV exposure will warp and fade components.**
- Retain all provided Packing Materials. All provided packing materials are for ease of repacking & component protection.

Disassembly

- For loss prevention, tighten all set screws and locks during disassembly.

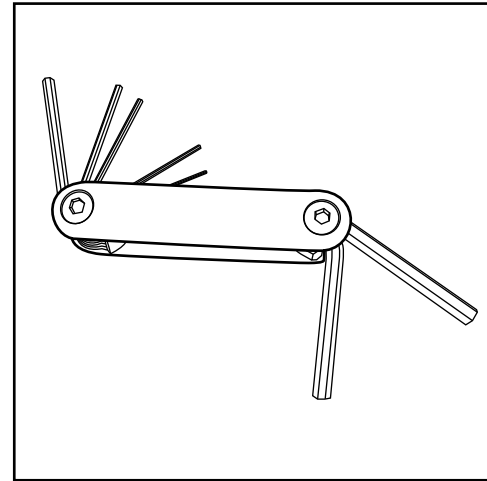

Hex Tool - Essential for Assembly

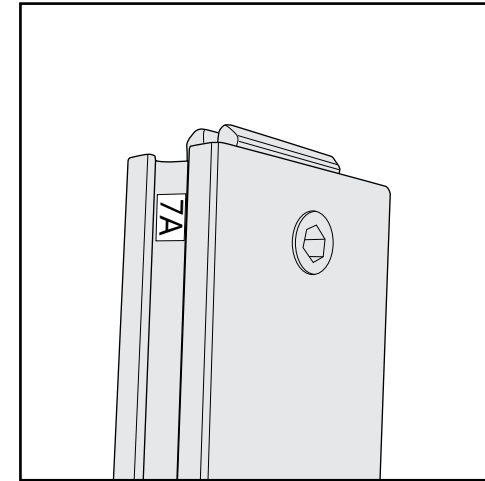

Part Identification - Numbering

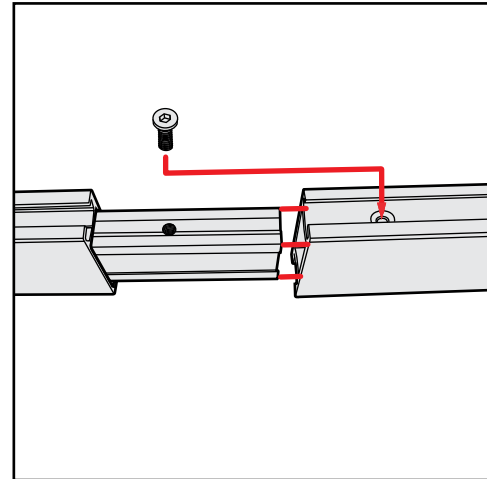

Spline Connection

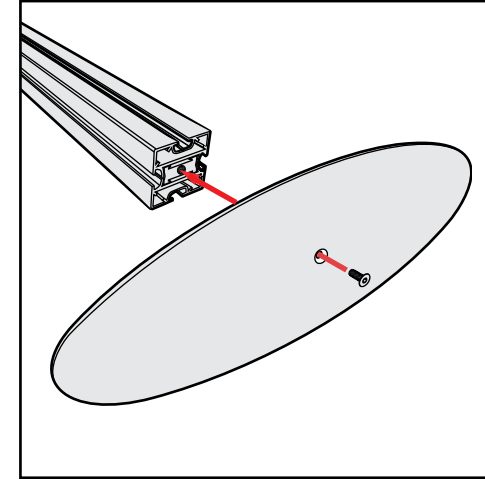

Base Plate & Extrusion Connection

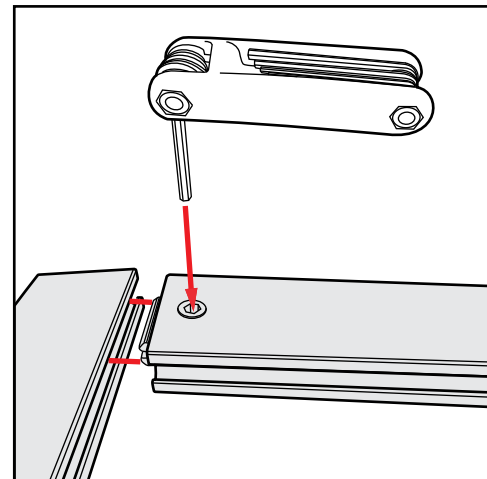

Extrusion & Lock Connection

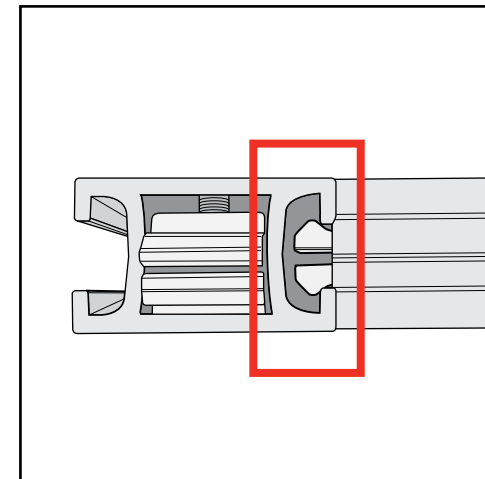

Engaged Lock



WARNING



DO NOT USE POWER TOOLS

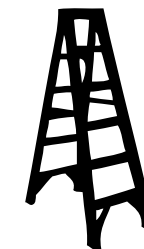

LADDERS OR LIFTS
MAY BE REQUIRED



ALL CONNECTIONS MUST
BE TIGHTLY SECURED

Top View of Each Level

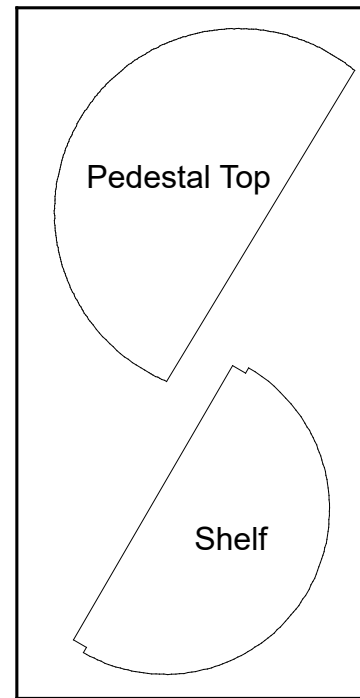

Level 1
(Bottom level)

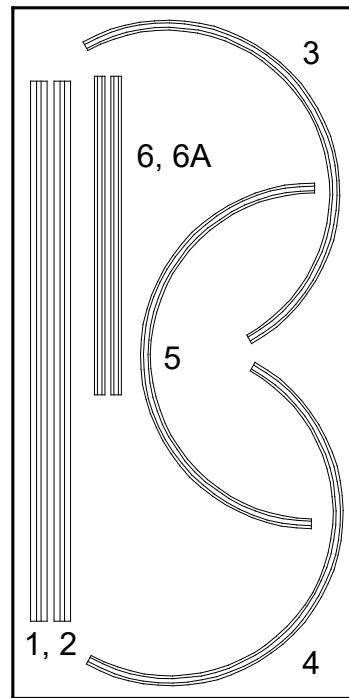

Level 2

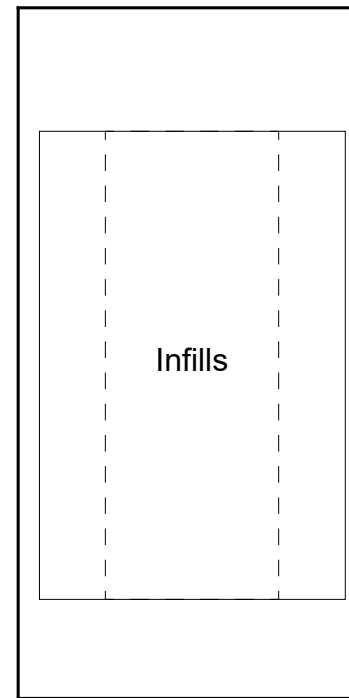

Level 3

